



ALFA SRL

ZENITH D - INSTALLATION INSTRUCTIONS

update 1.0
06/2011

GLASS DOOR
solutions D1 and DD1

D1.00

ZENITH D1 - DD1
INSTALLATION INSTRUCTIONS
GLASS DOOR

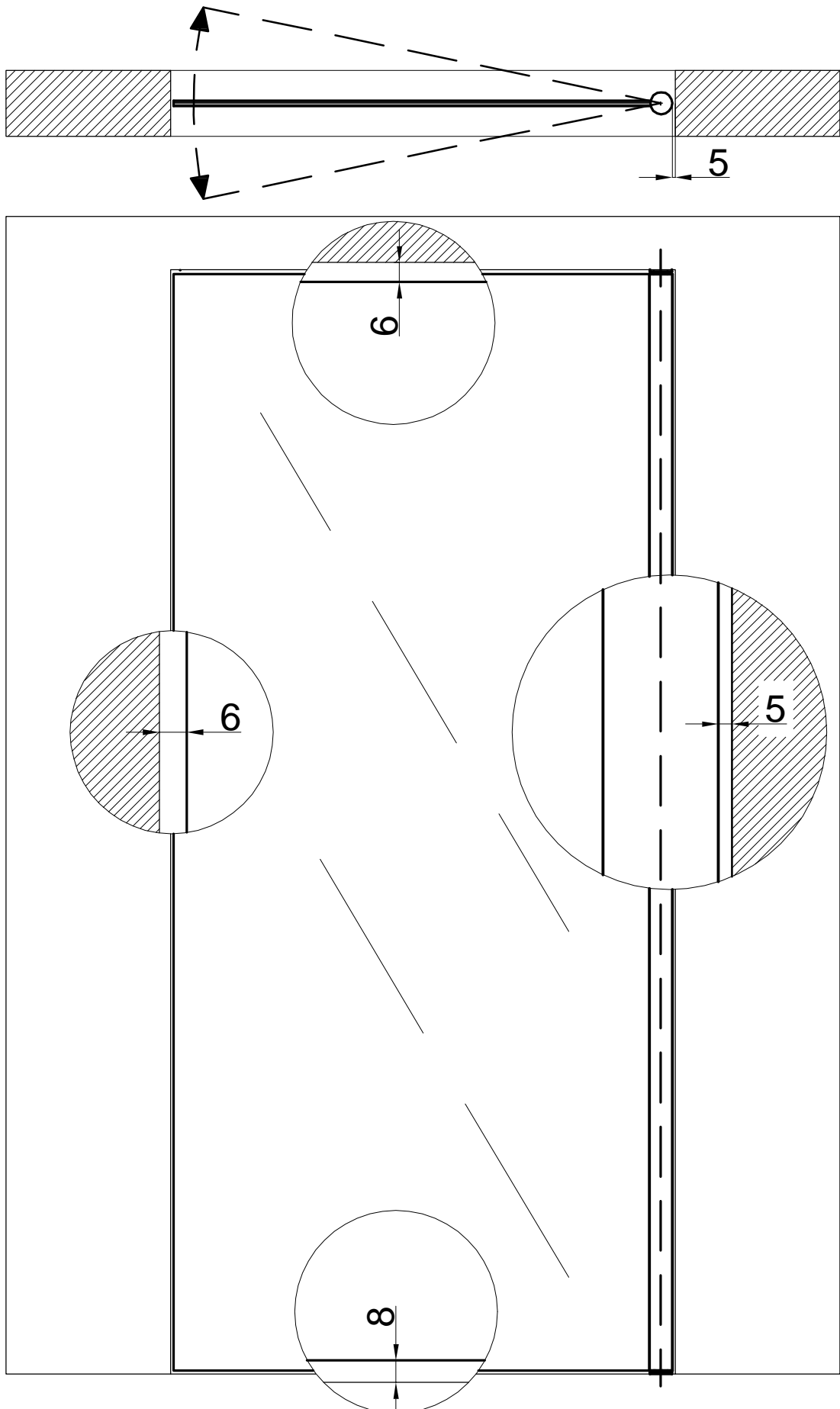

D1.01

ZENITH D1 - APPLICATION ON SINGLE GLASS DOOR

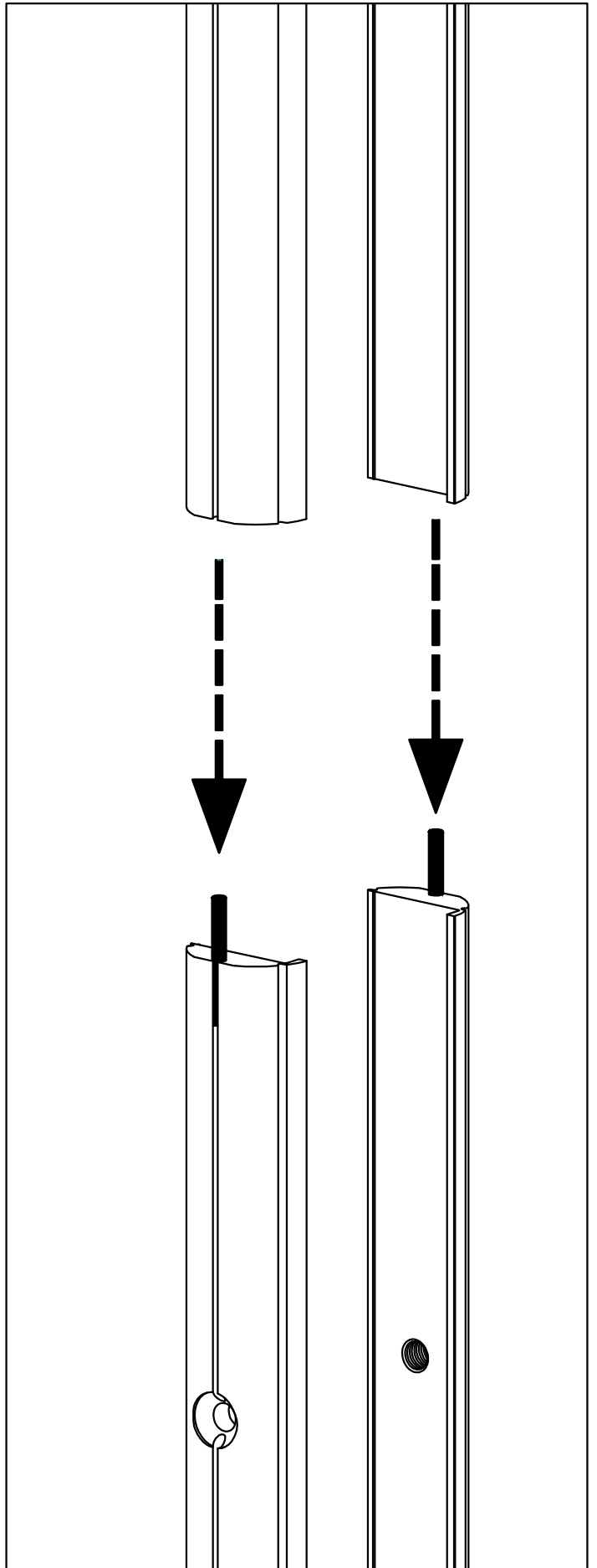
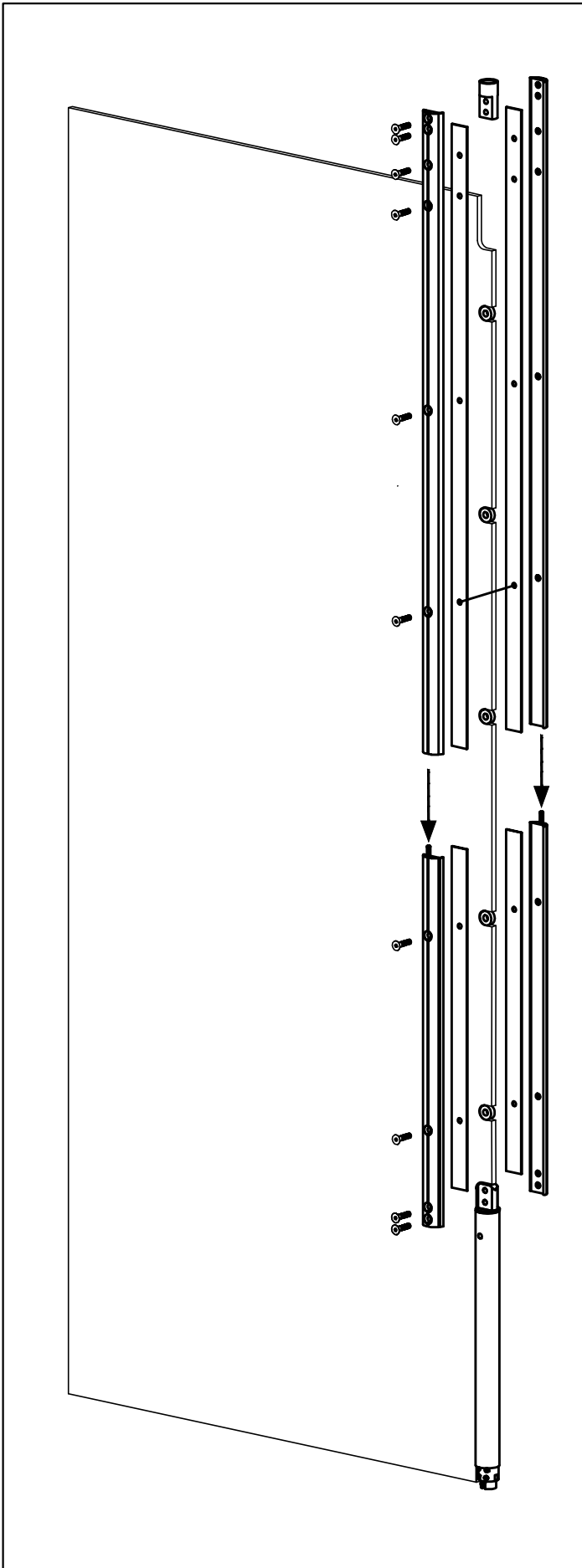

D1.02

ZENITH D1 - BEFORE THE INSTALLATION OF THE DOOR, FASTENING ALUMINIUM BARS AND MOUNTING THE SYSTEM ON THE GLASS DOOR

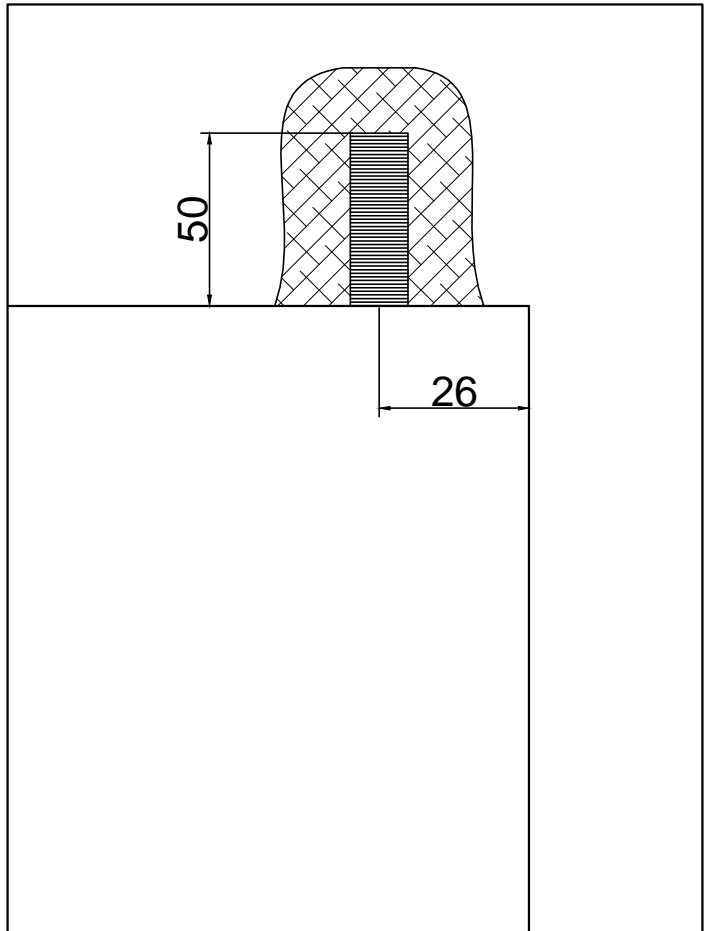
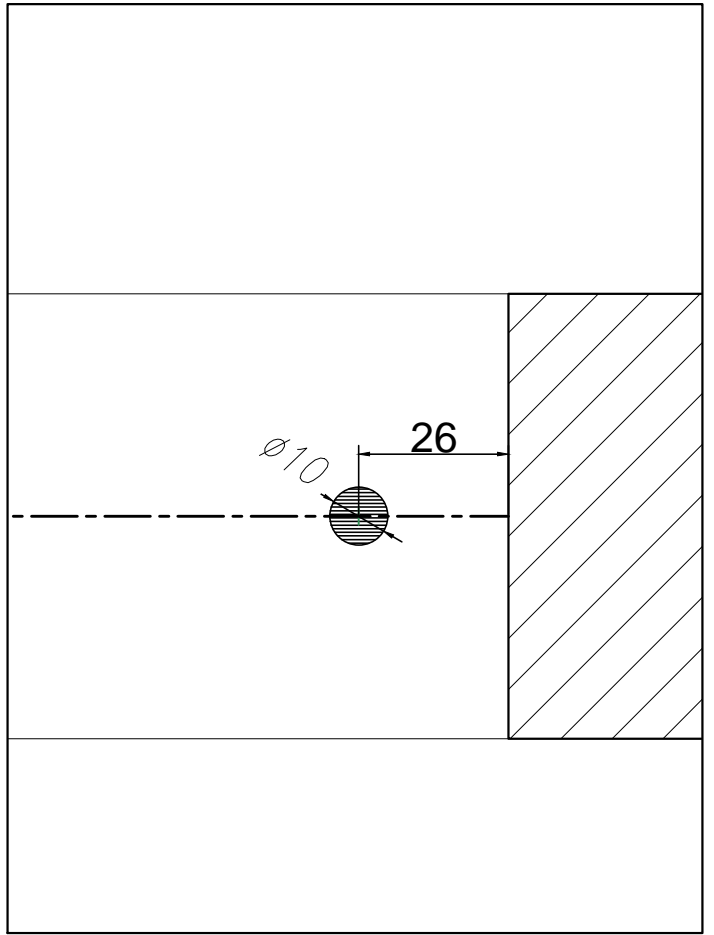
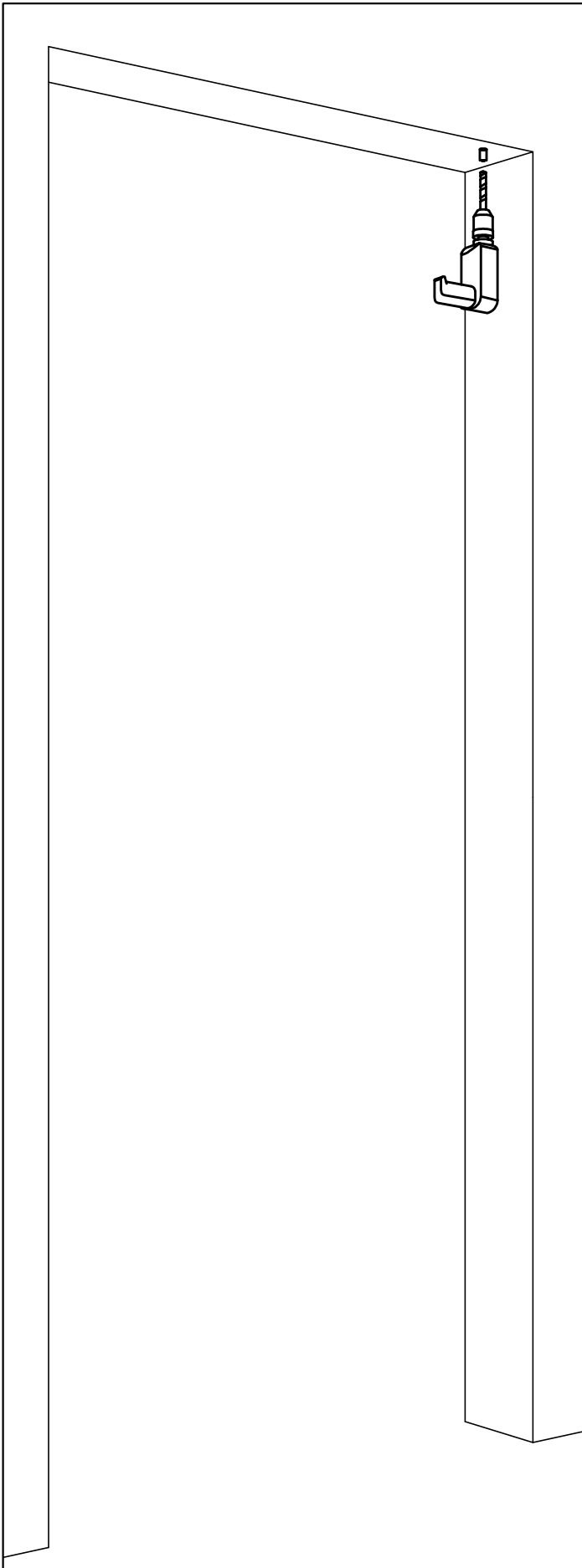

D1.03

ZENITH D1 - HOLE FOR TOP WALL ACCESSORY

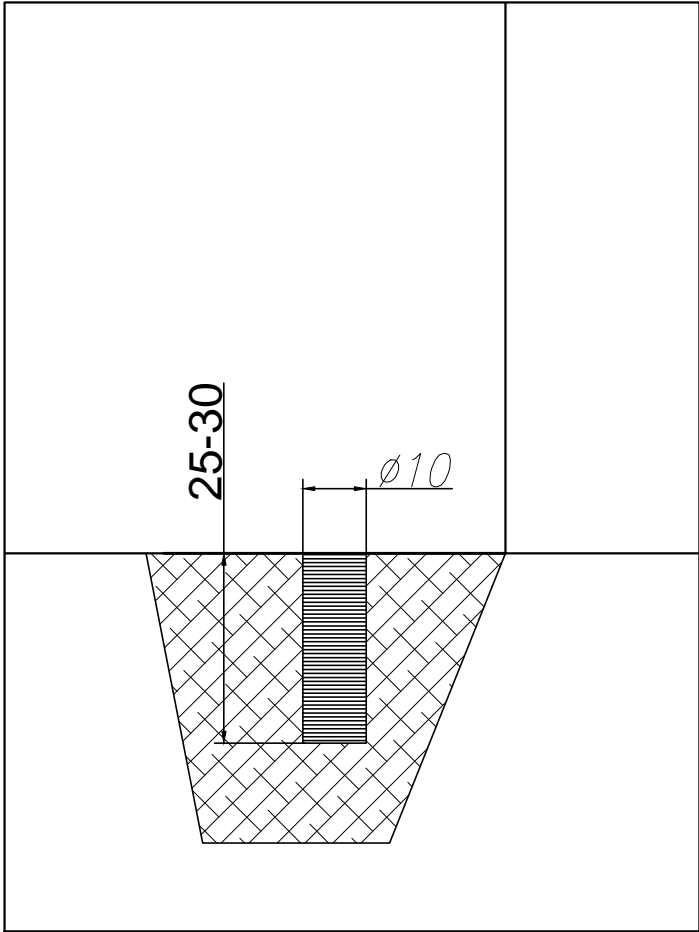
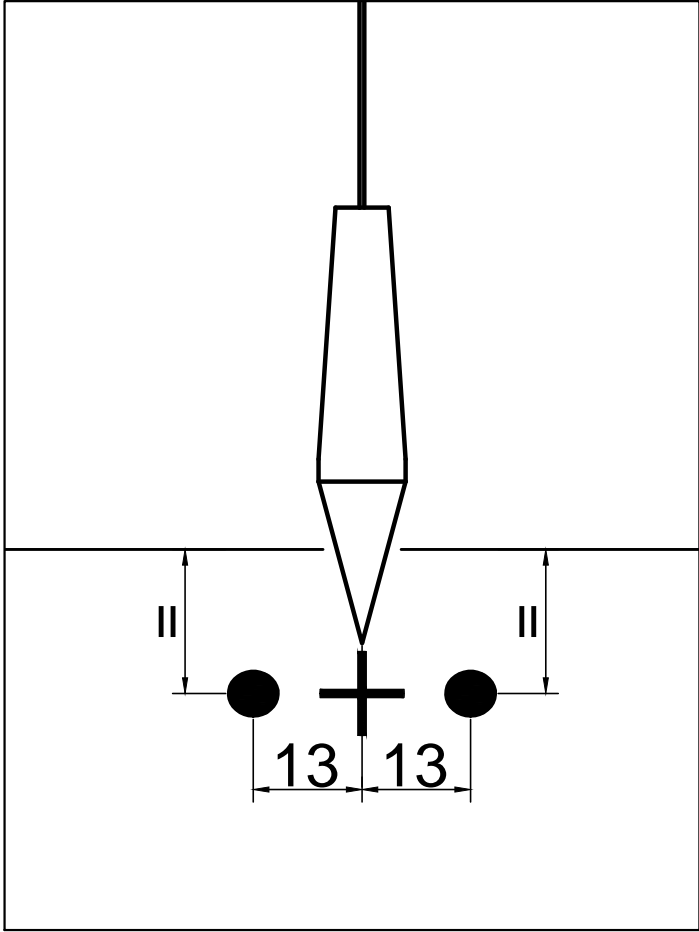
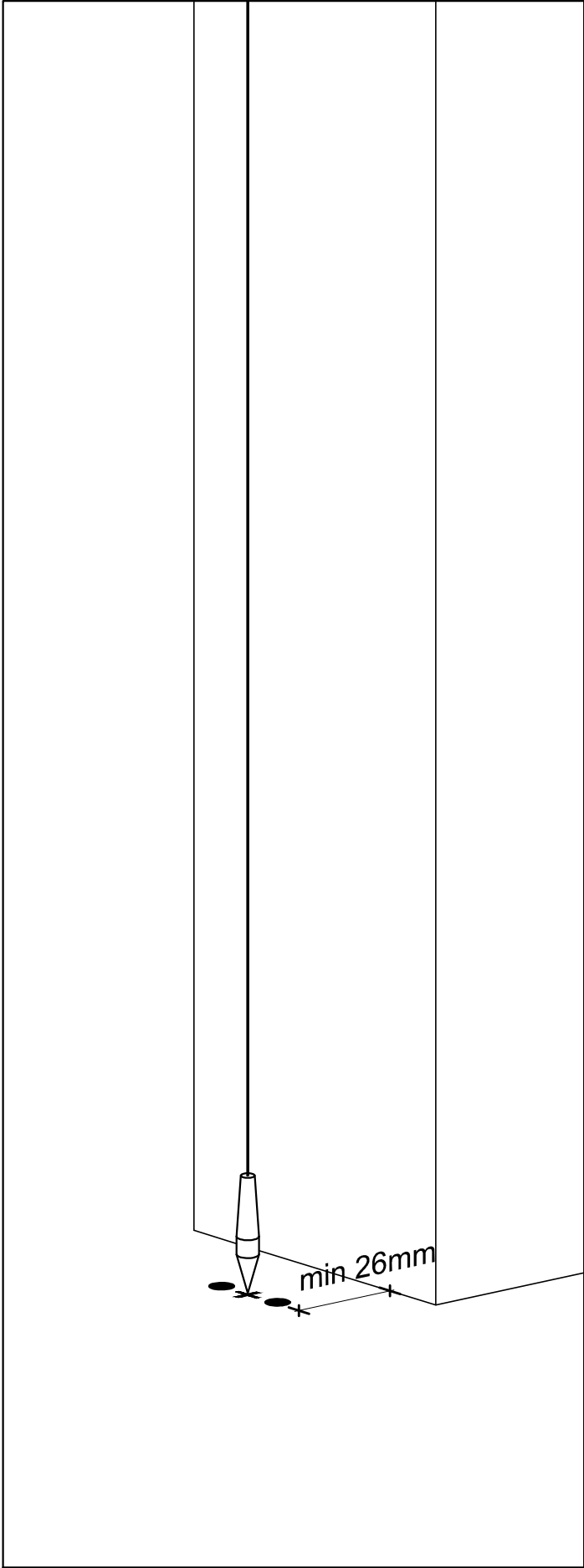

D1.04

ZENITH D1 - HOLE FOR BOTTOM ACCESSORY

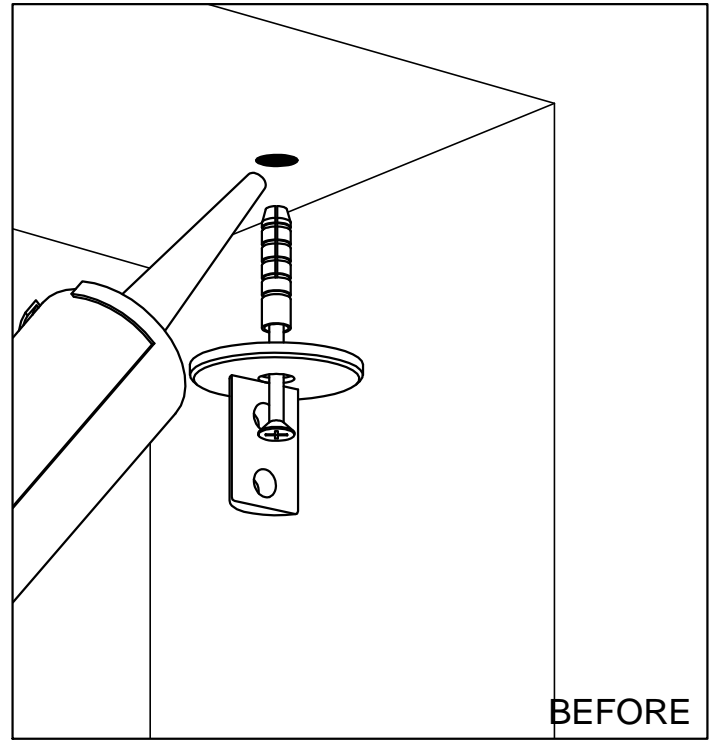
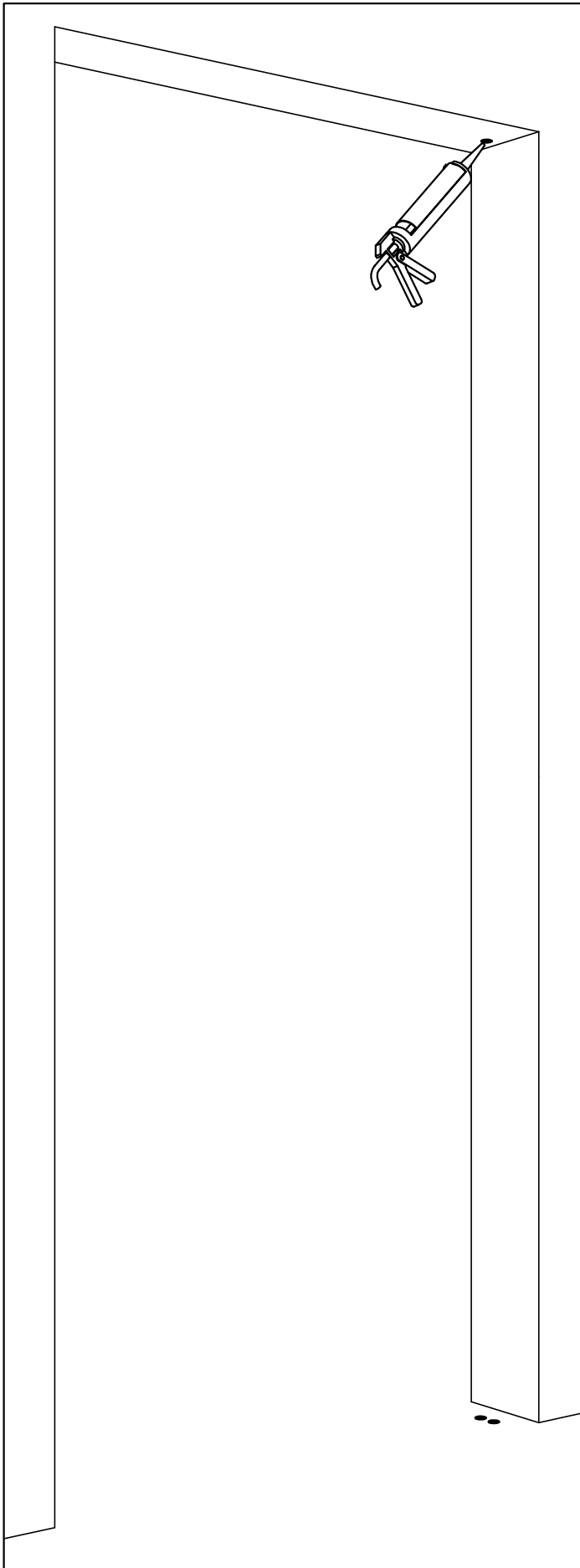

FIX IMMEDIATELY IN POSITION WITH THE STEEL DOWEL

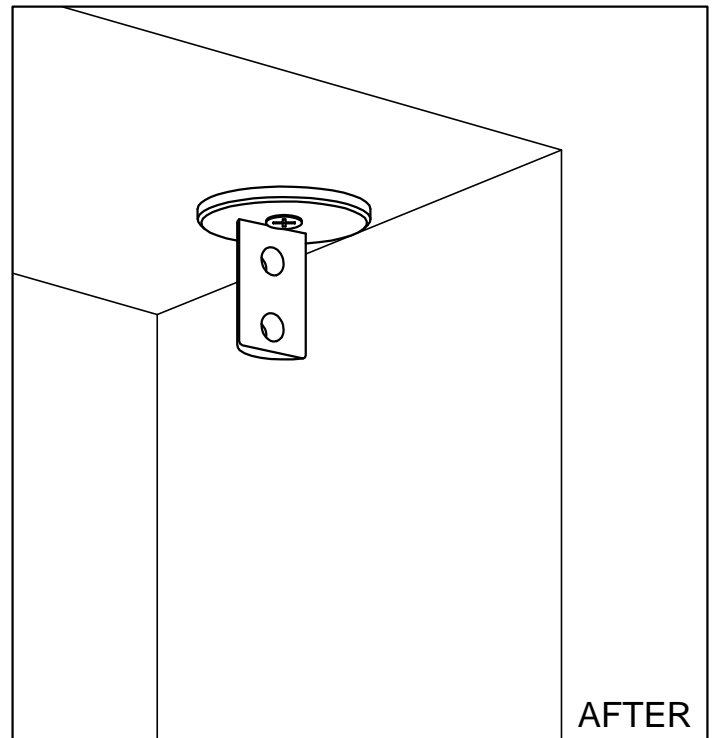

D1.05

ZENITH D1 - MAKE A GOOD CLEANING OF HOLES.
FILLED UP HOLES WITH A CHEMICAL RESIN TO FIX THE TOP ACCESSORIES
(THE CHEMICAL RESIN FISHER FIS B 390 S IS SUGGESTING)

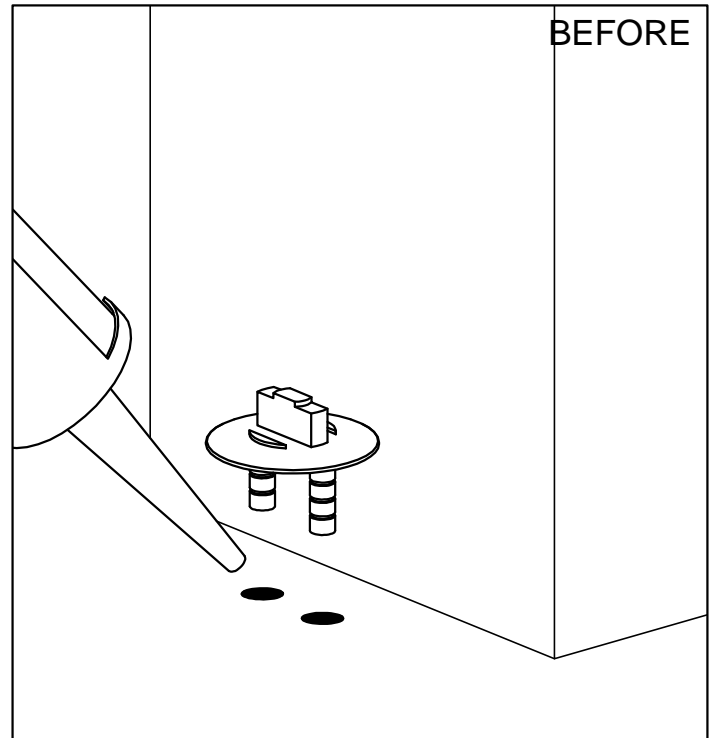
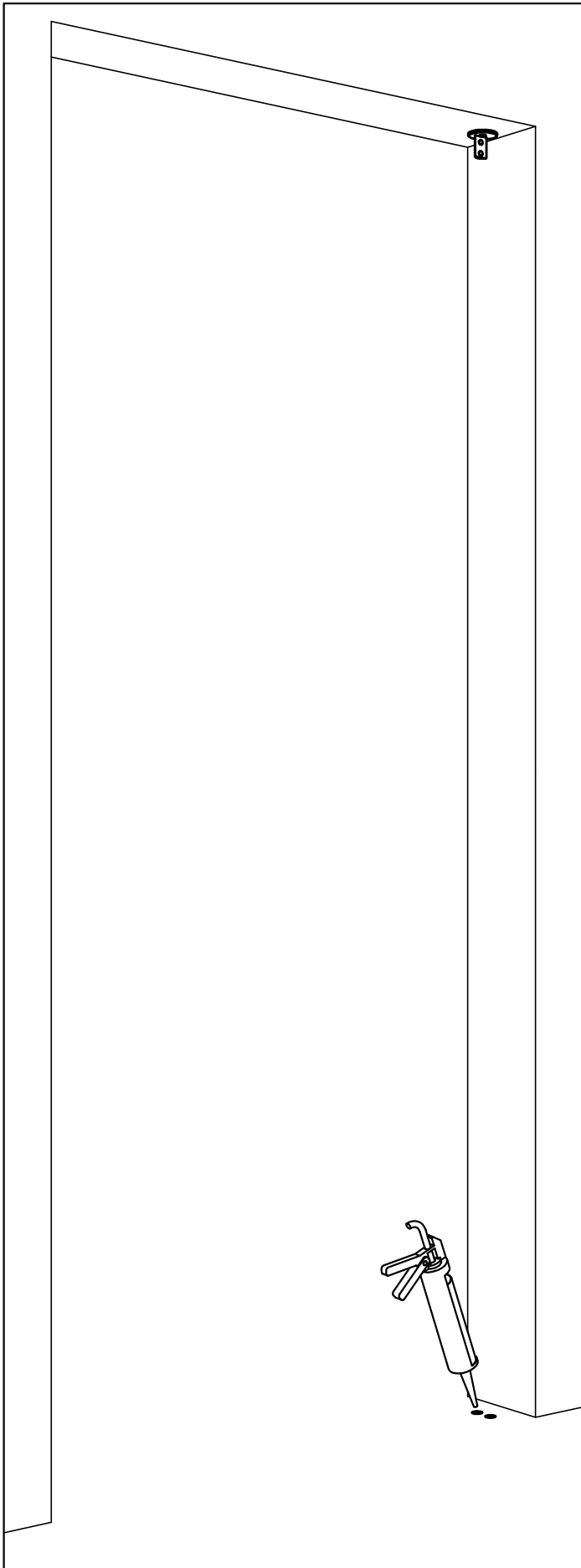

EQUIPPED FOR LEADWORK BEFORE HARDENING OF
THE CHEMICAL RESIN

(5 minutes)

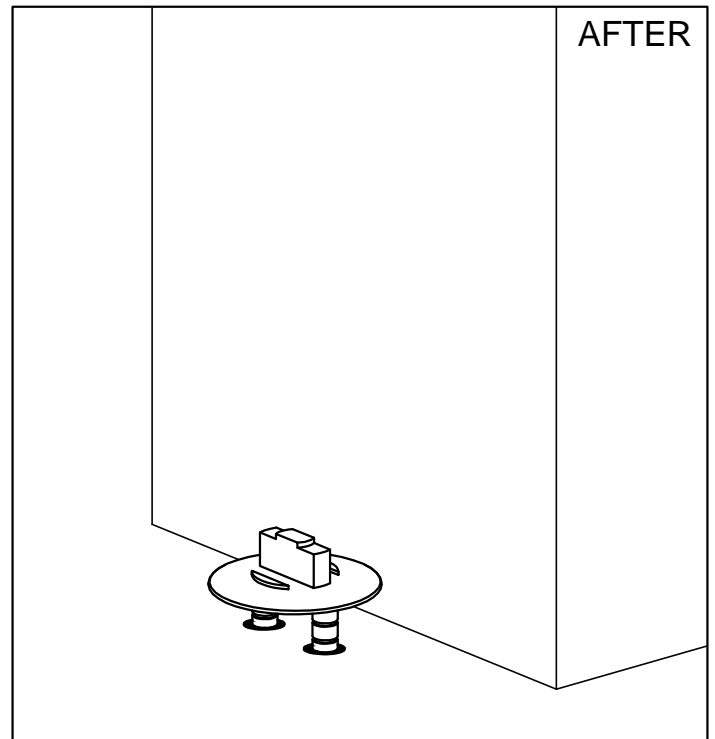

D1.06

ZENITH D1 - FINALLY FILLED UP HOLES WITH A CHEMICAL RESIN TO FIX
THE BOTTOM ACCESSORIES

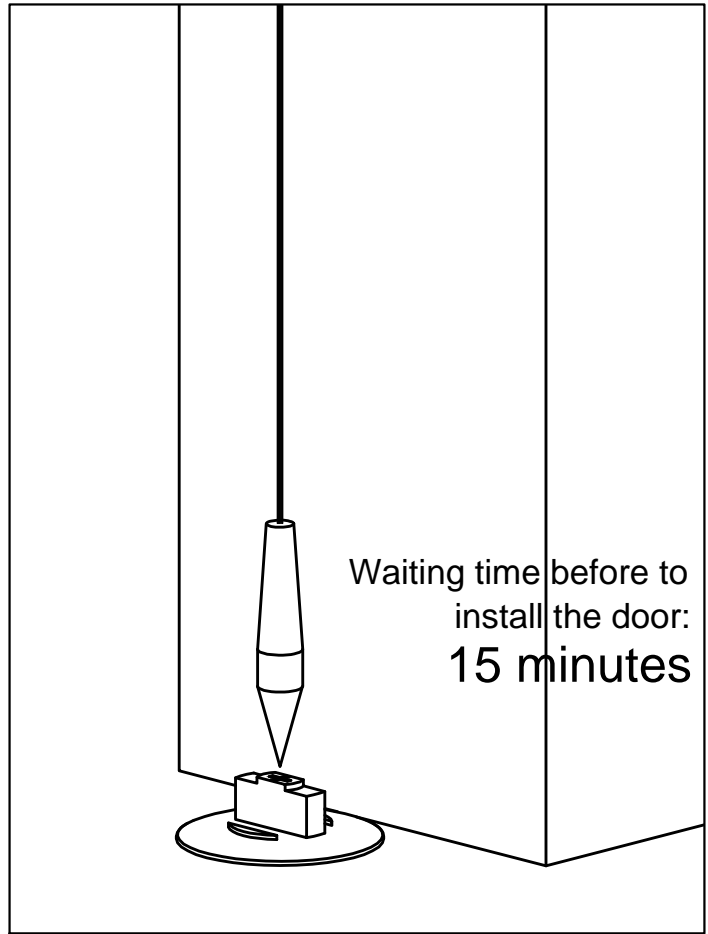
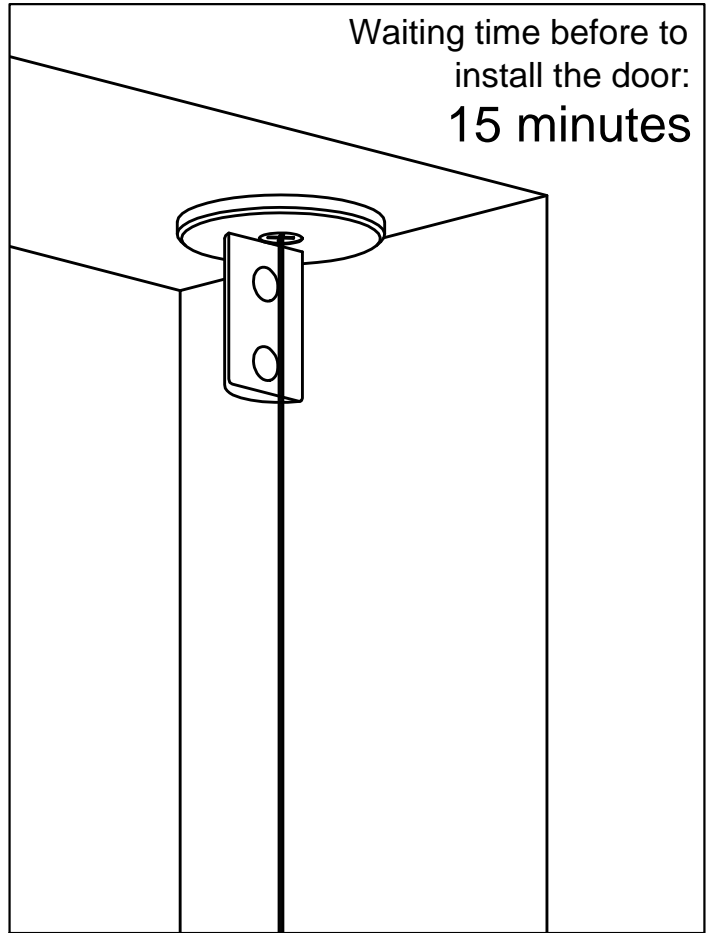
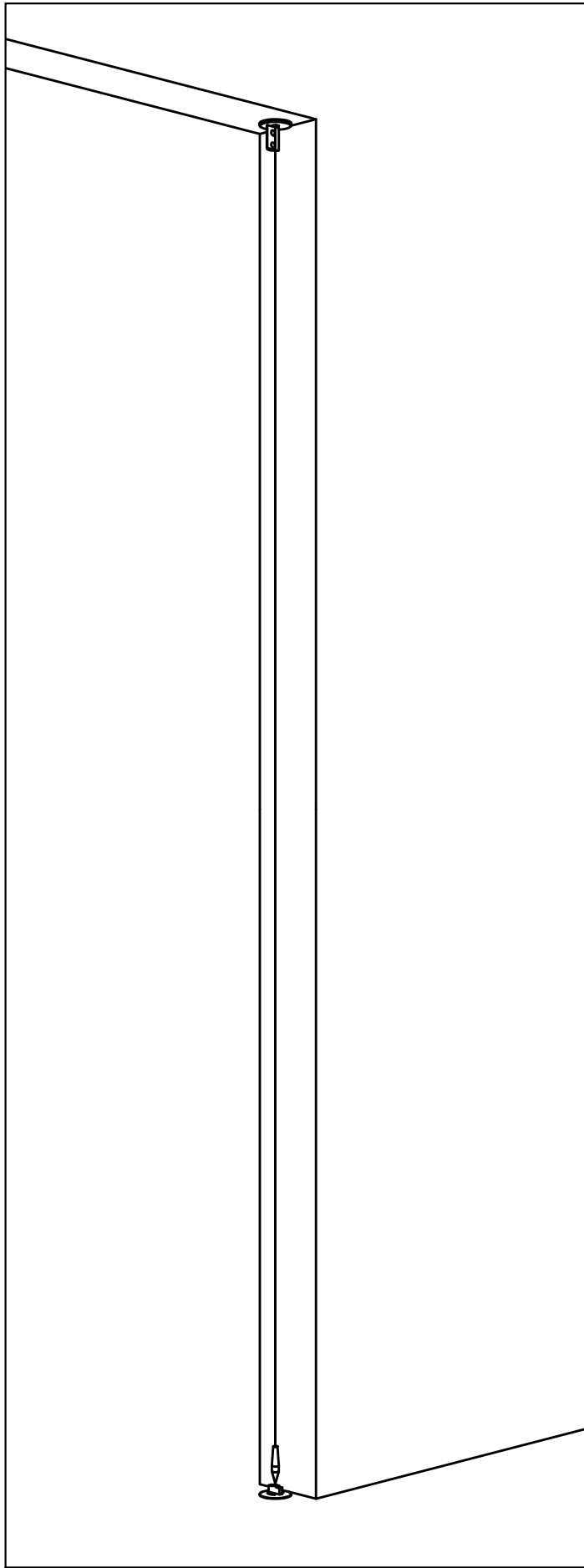

D1.07

ZENITH D1 - TOP AND BOTTOM ACCESSORIES MUST BE PERPENDICULAR TO EACH OTHER.

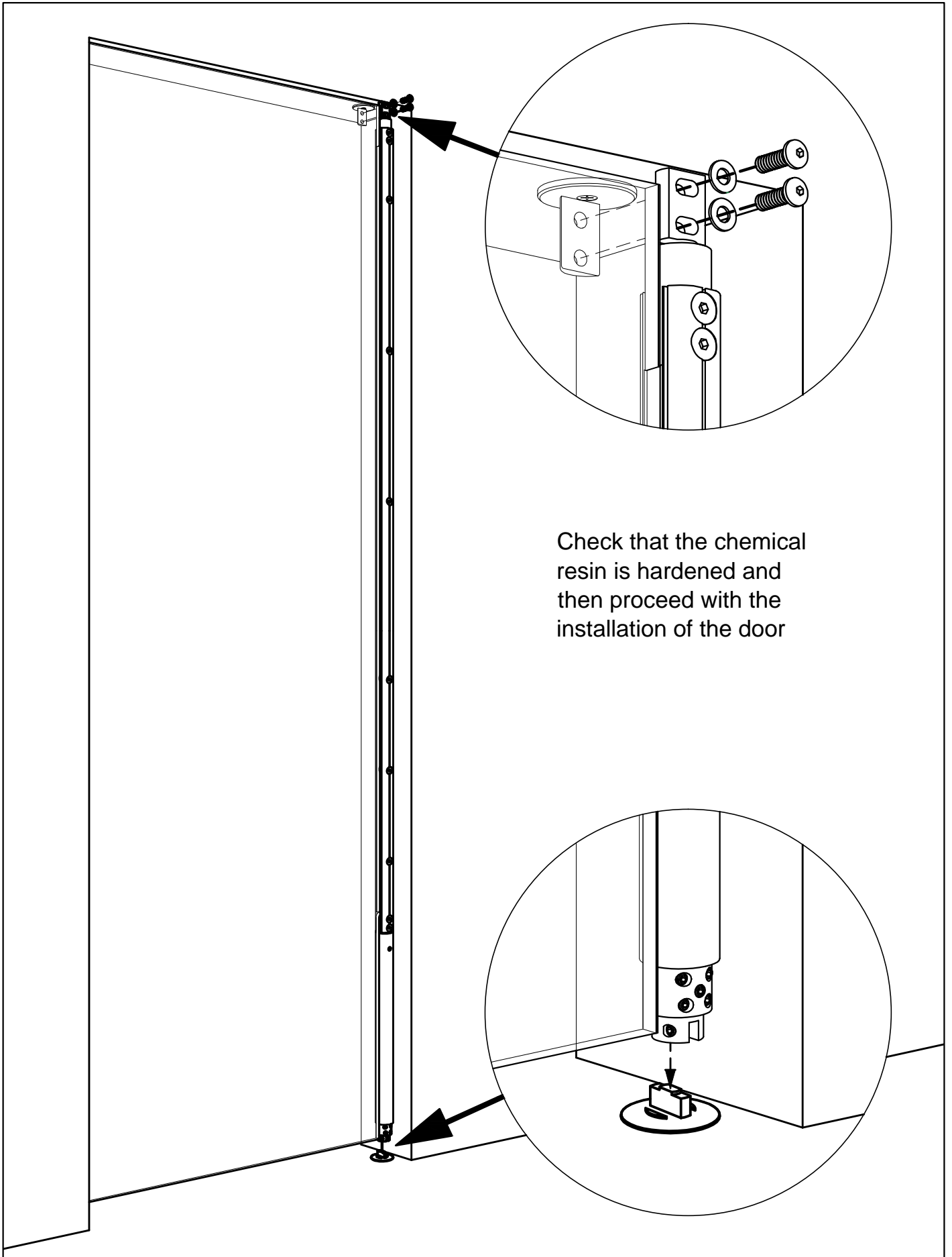

Check that the chemical resin is hardened and then proceed with the installation of the door

D1.08

ZENITH D1 - INSERT THE GLASS DOOR AS INDICATED.

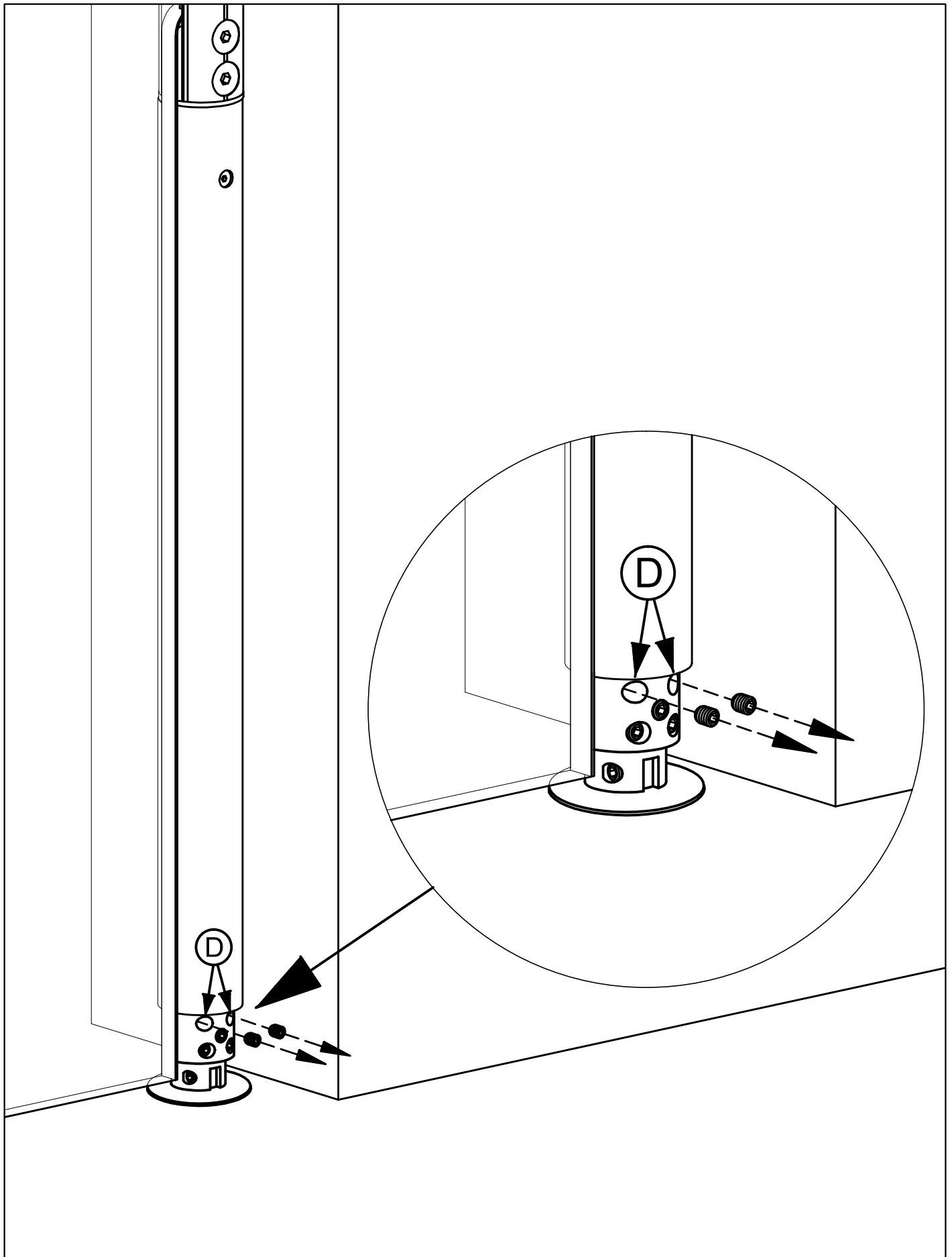

D1.09

ZENITH D1 - TAKE OUT THE SCREWS "D" BEFORE TO MAKE THE
ADJUSTMENT OF THE DOOR.

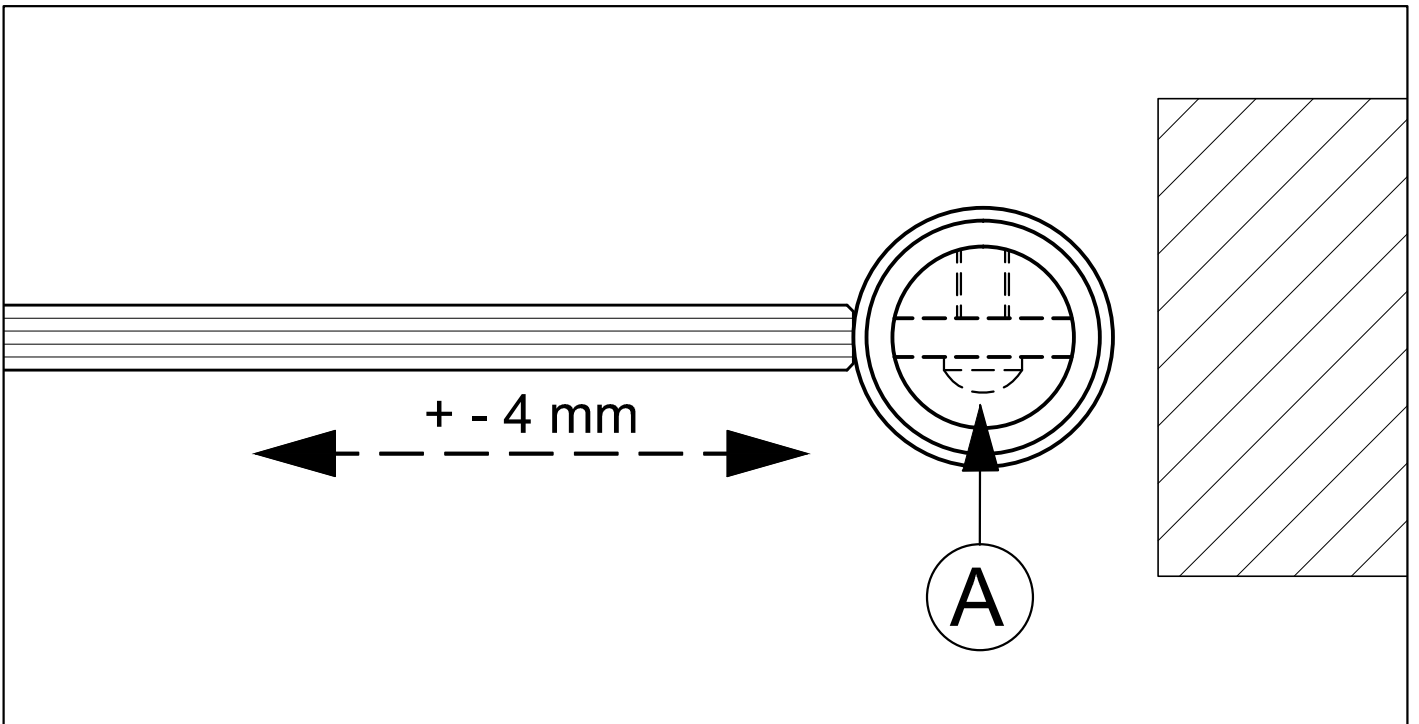
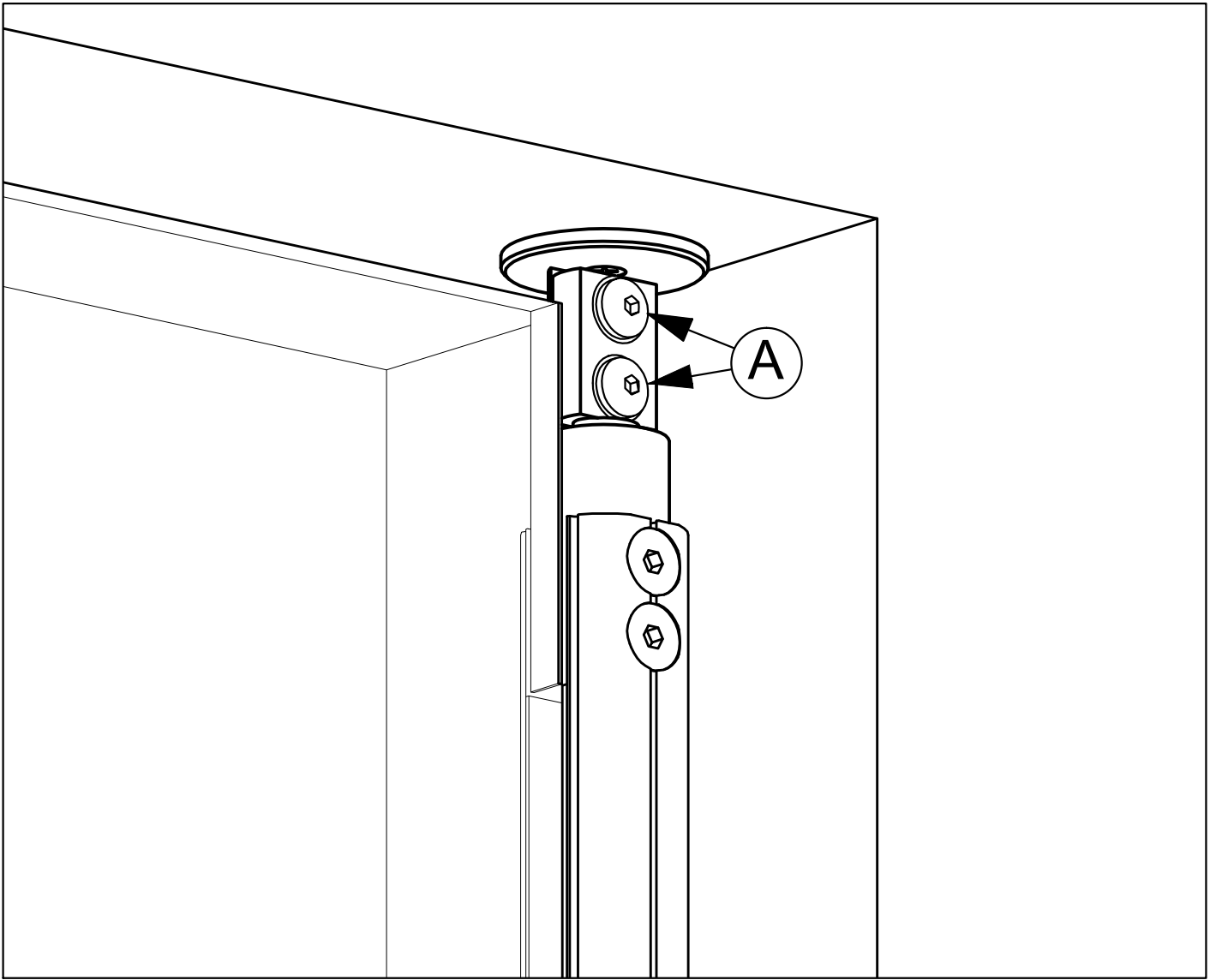

D1.10

ZENITH D1 - ADJUSTMENT "A" TOP HINGE

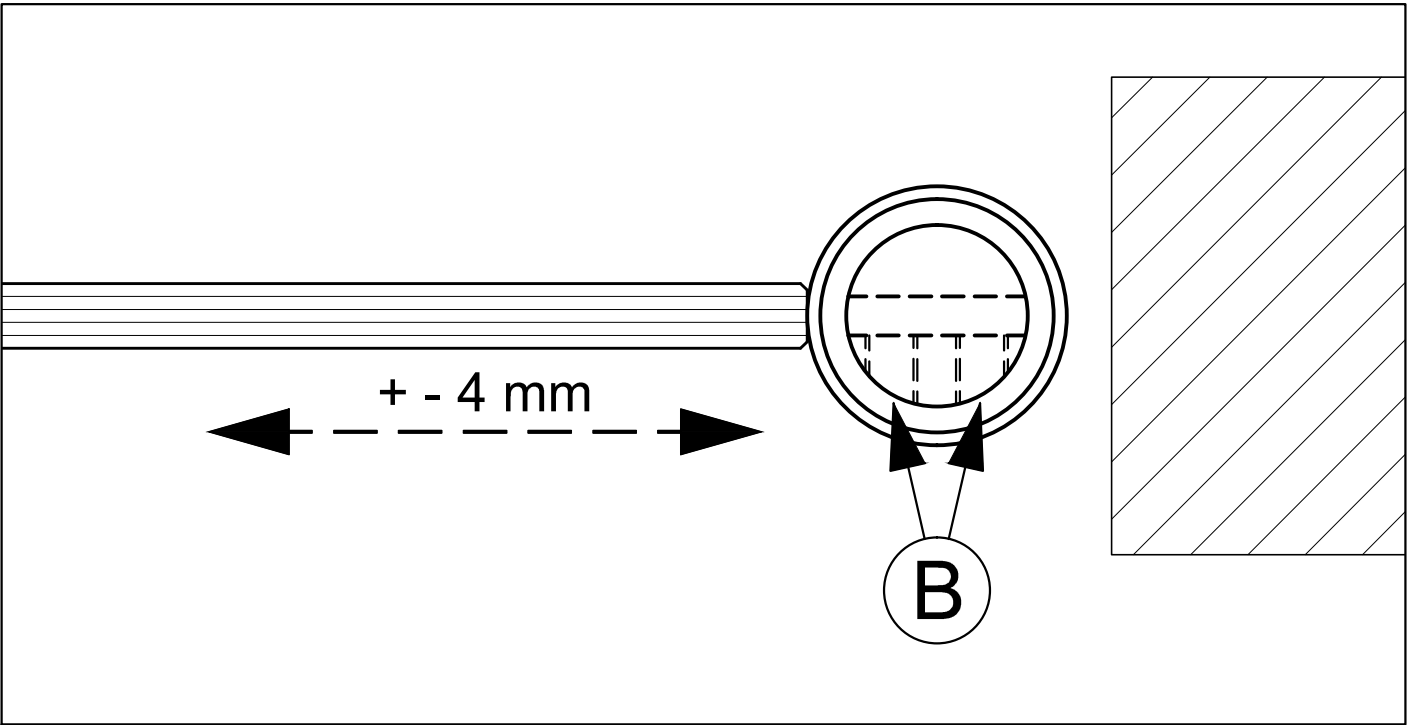
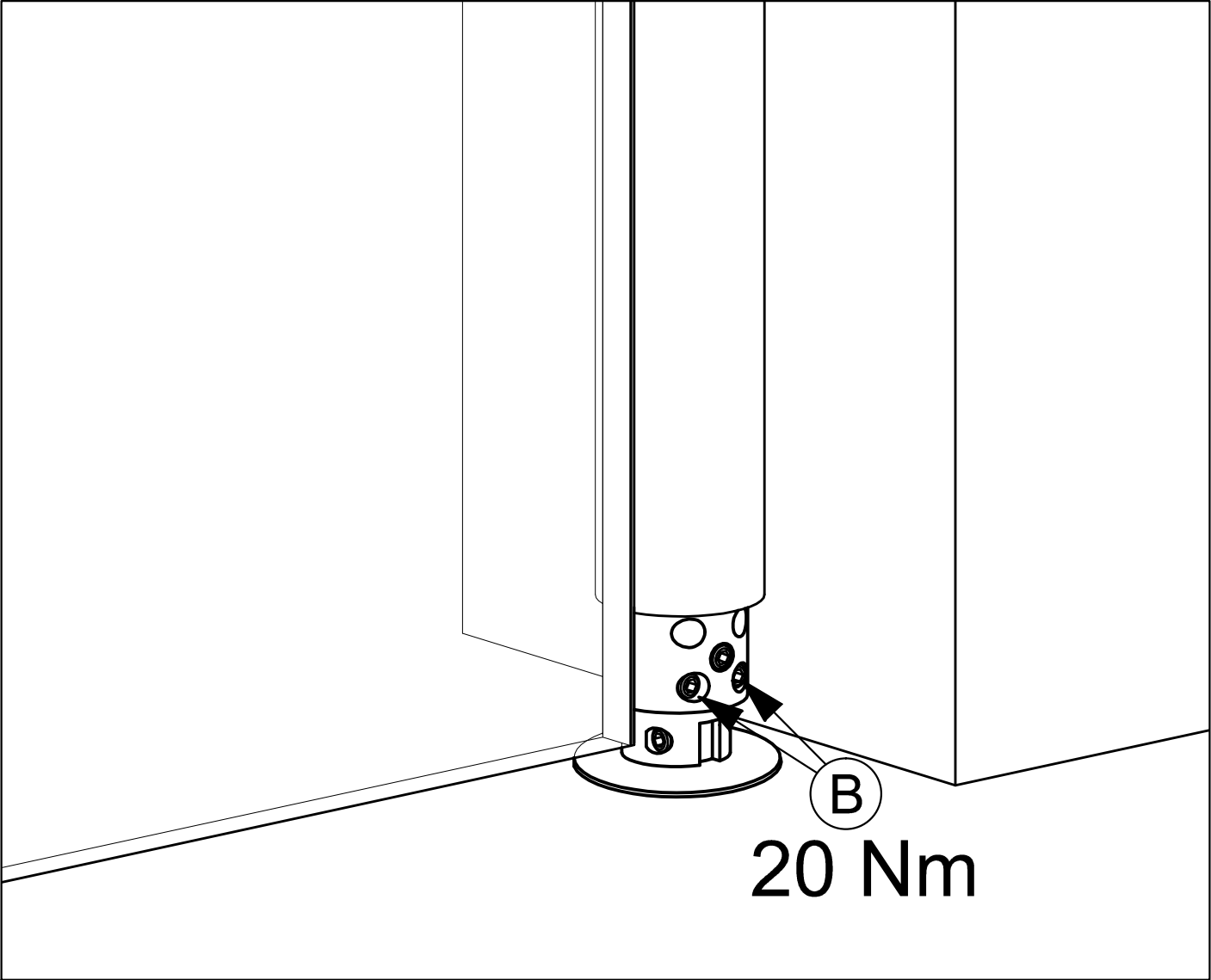

| | |
|-------|---|
| D1.11 | ZENITH D1 - ADJUSTMENT "B" BOTTOM HINGE |
|-------|---|

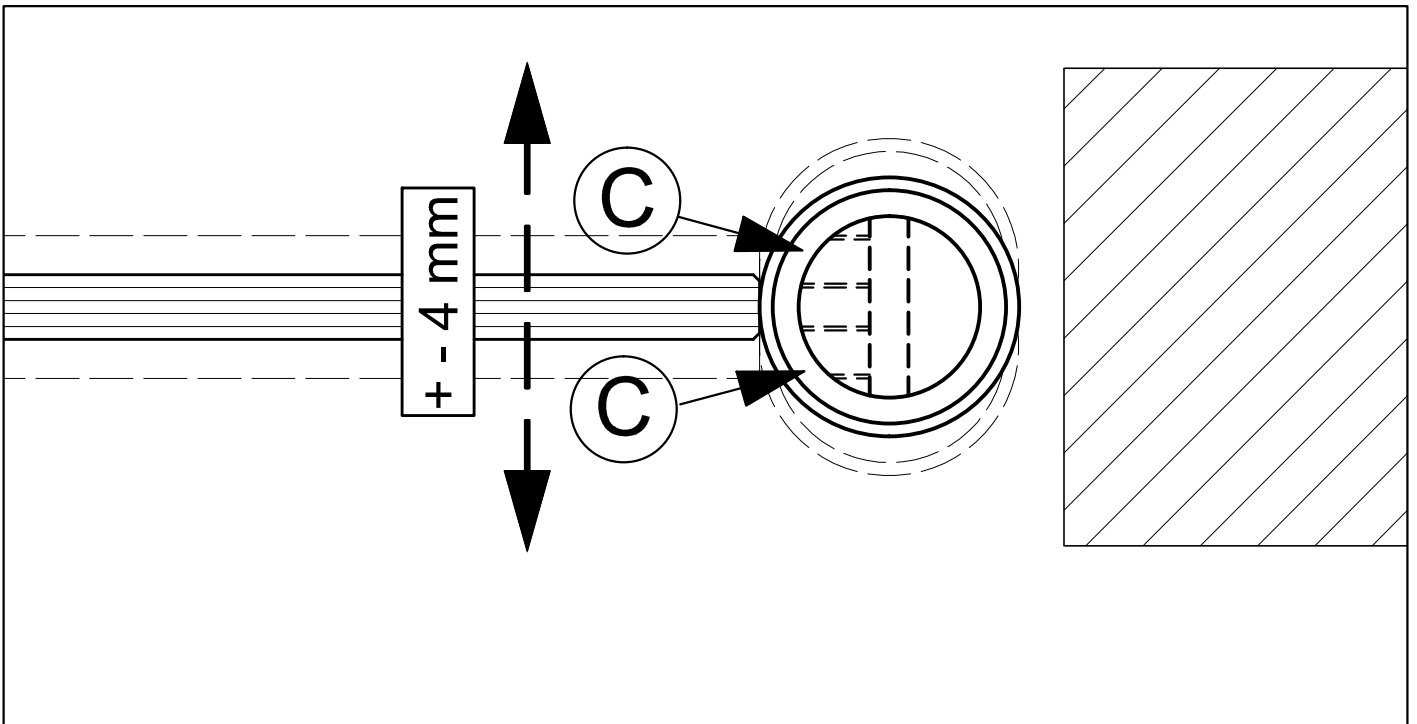
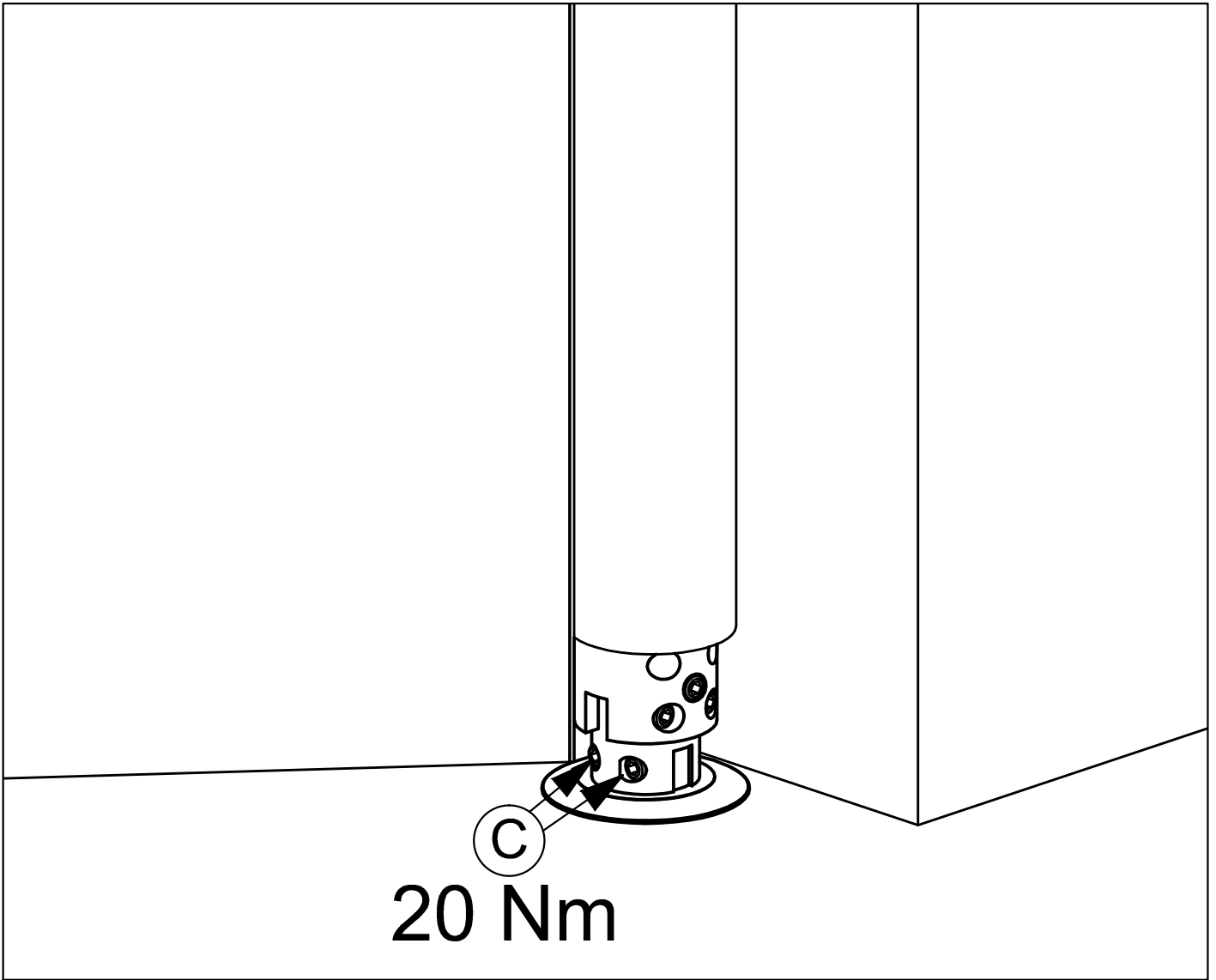

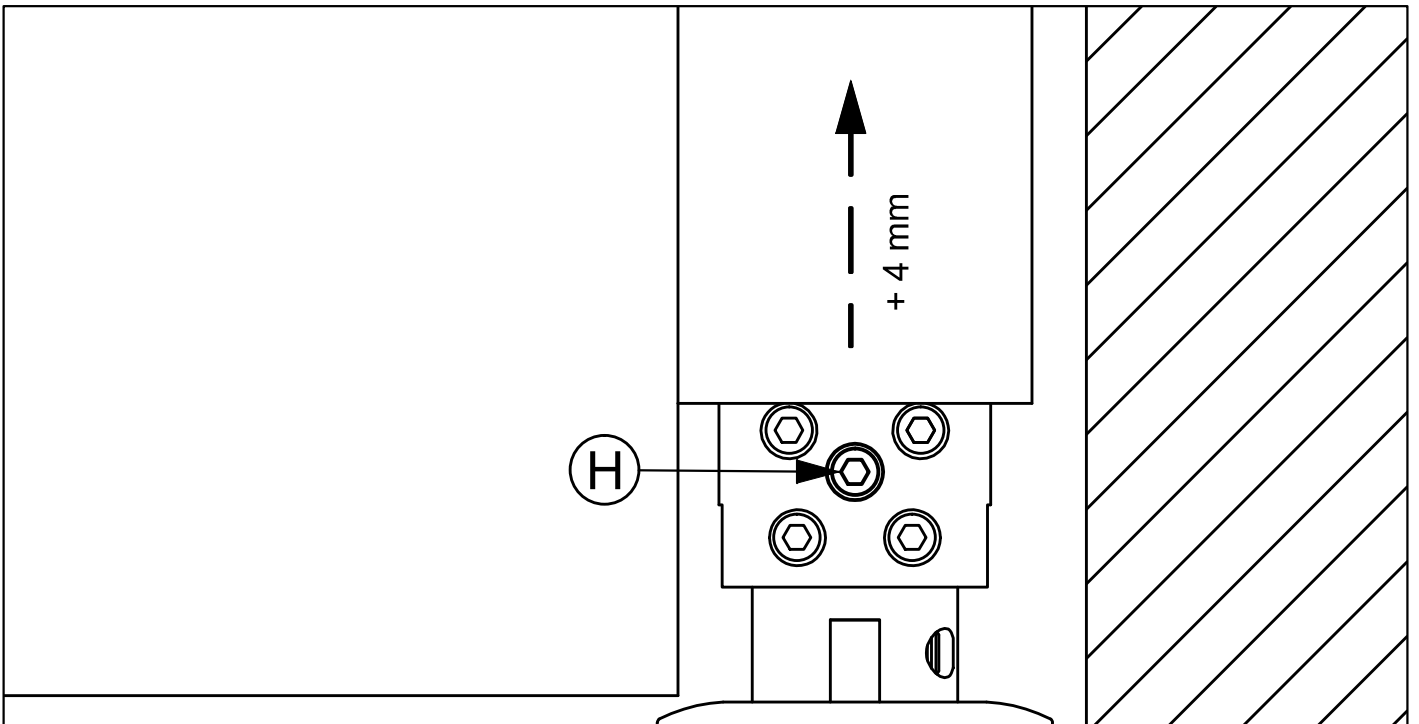
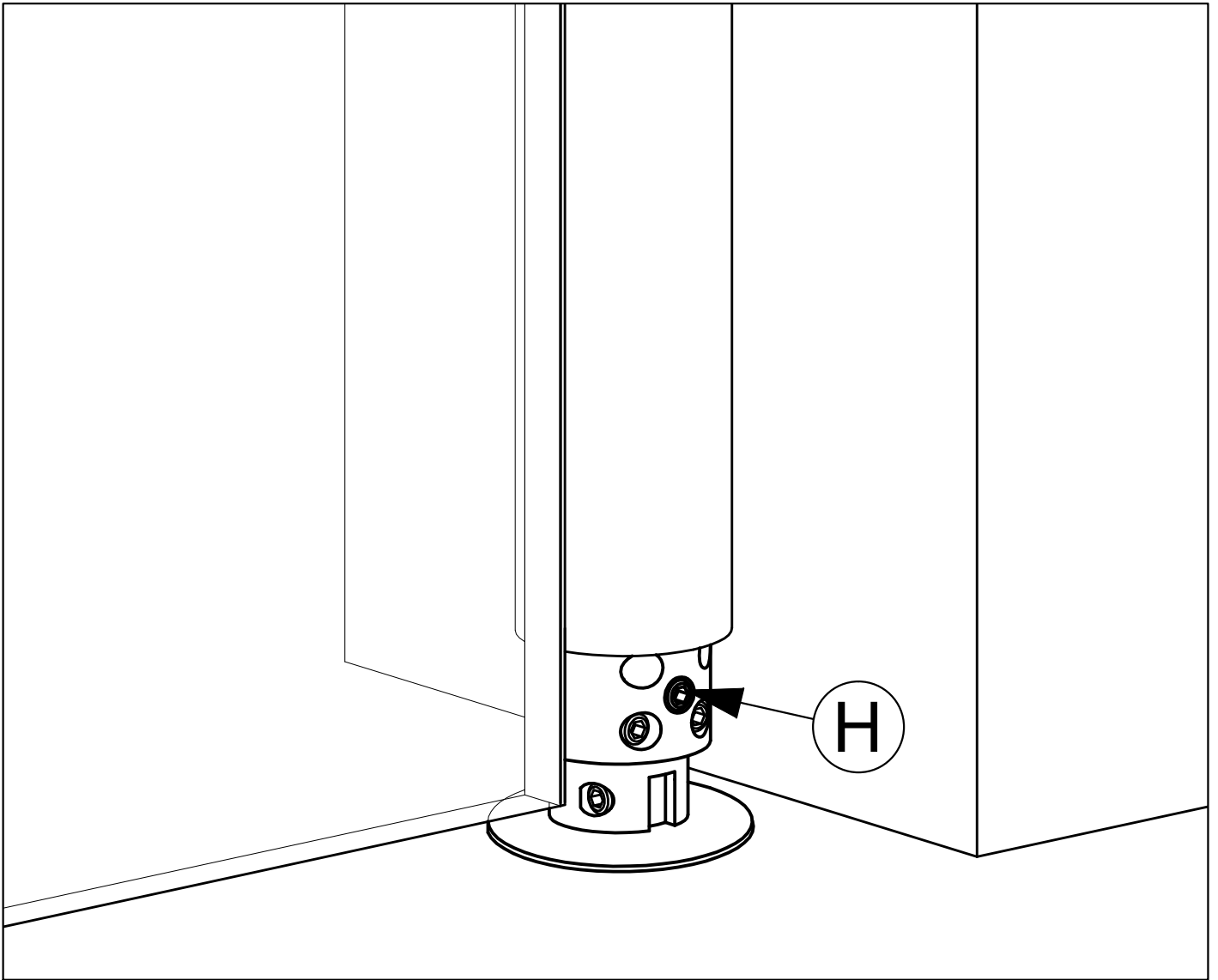

D1.13

ZENITH D1 - ADJUSTMENT "H" BOTTOM HINGE

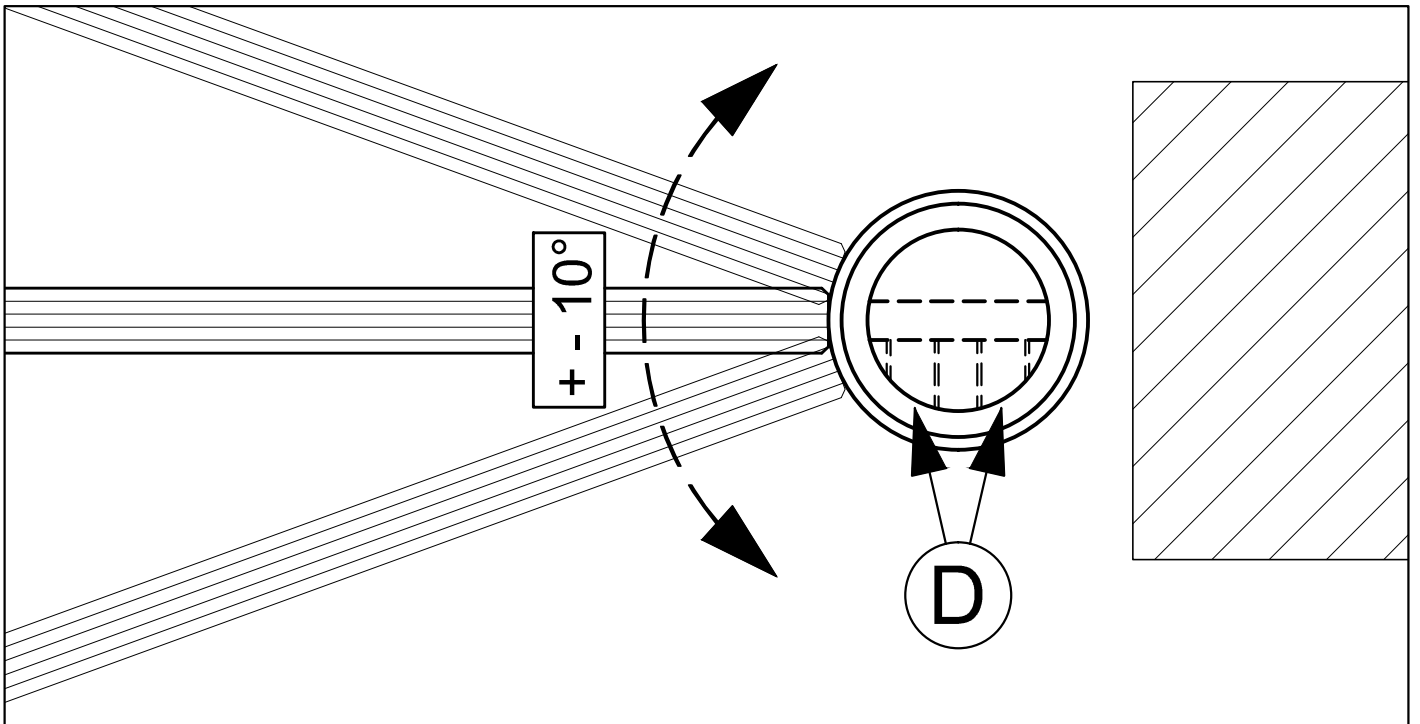
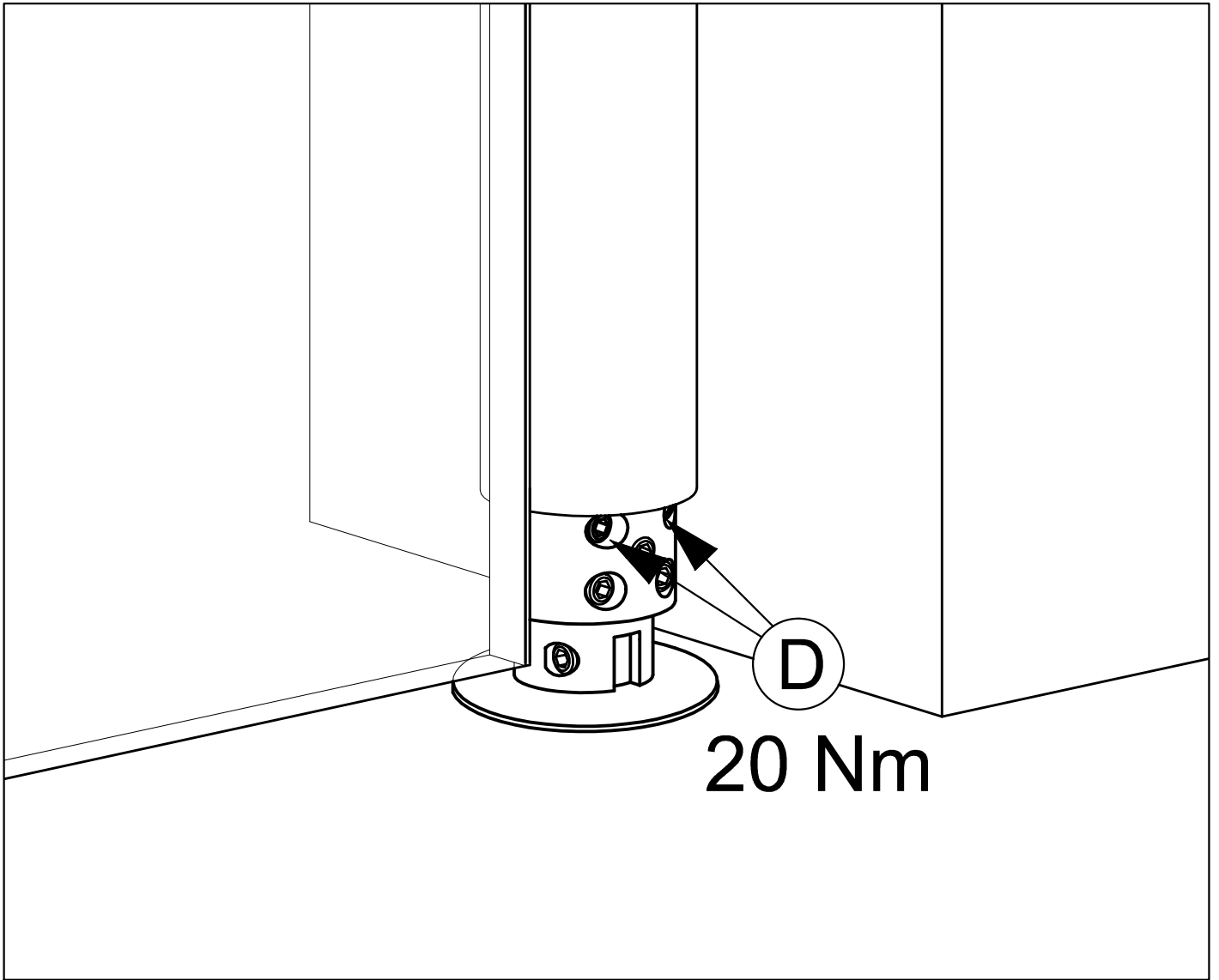

D1.14

ZENITH D1 - ADJUSTMENT "D" BOTTOM HINGE

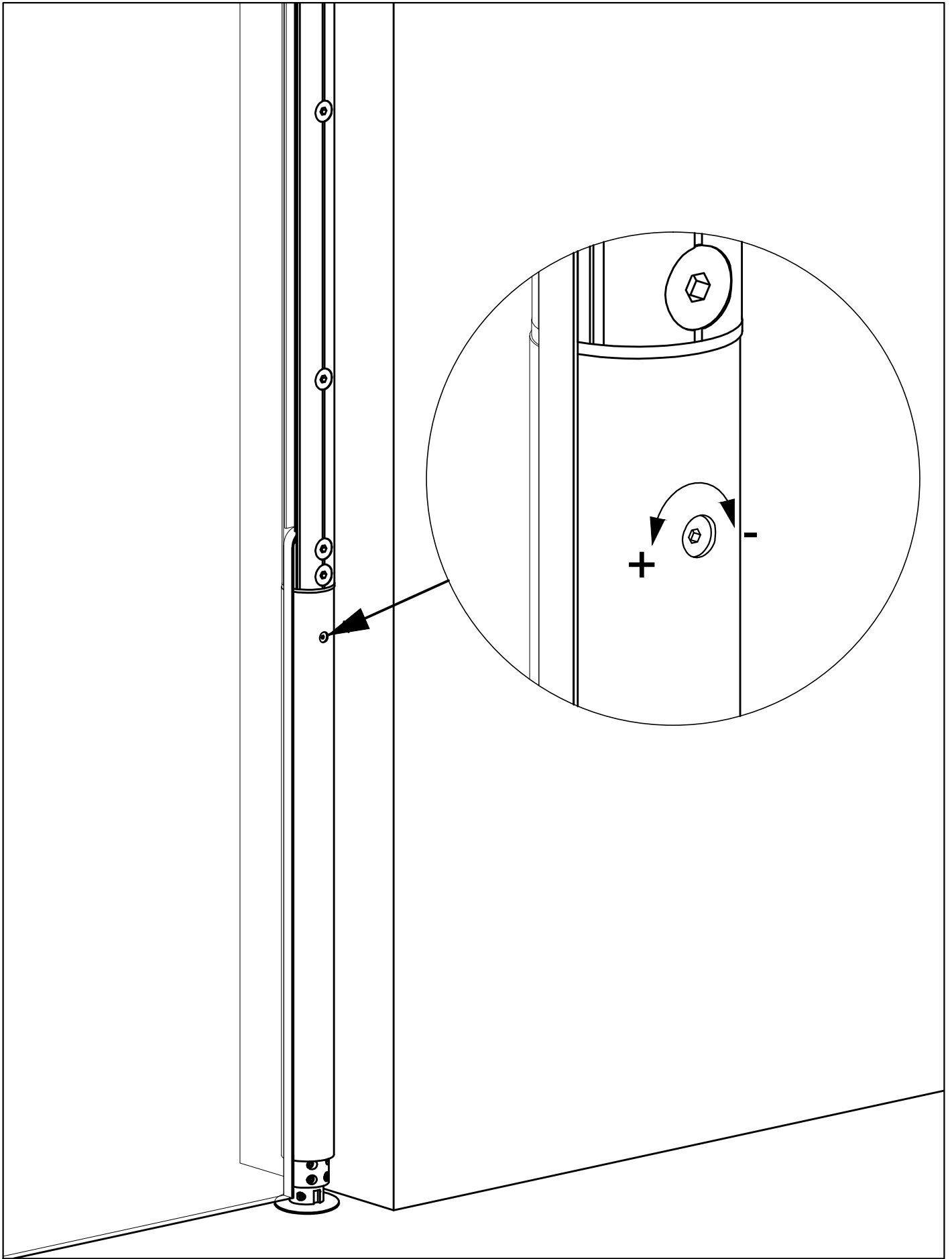

D1.15

ZENITH D1 - ADJUSTMENT CLOSING SPEED

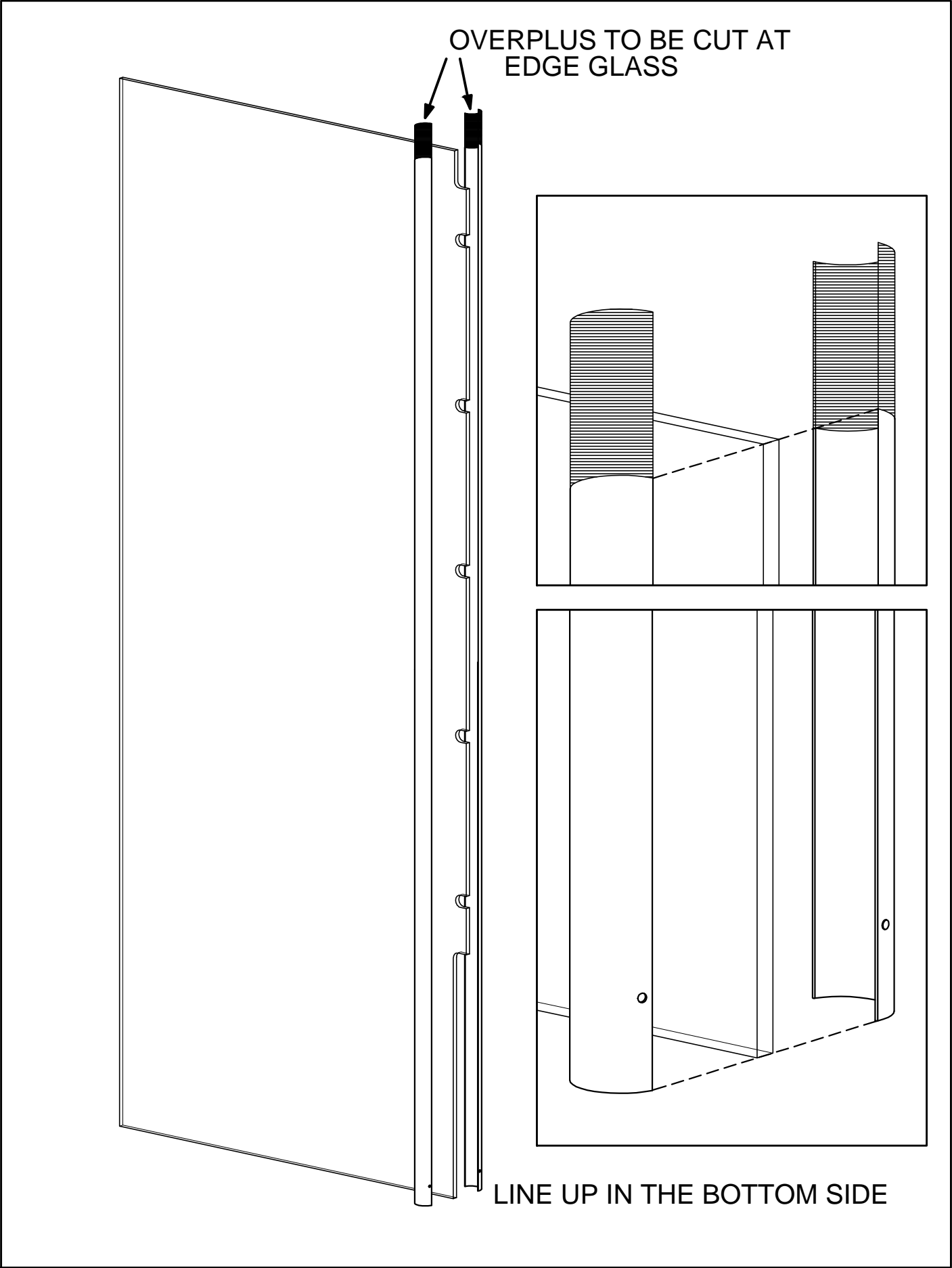

| | |
|-------|--|
| D1.16 | ZENITH D1 - CUTTING OF COVER PLATES LINE UP COVERPLATES AT THE BOTTOM SIDE OF THE GLASS DOOR AND CUT THE OVERPLUS IN THE TOP SIDE. |
|-------|--|

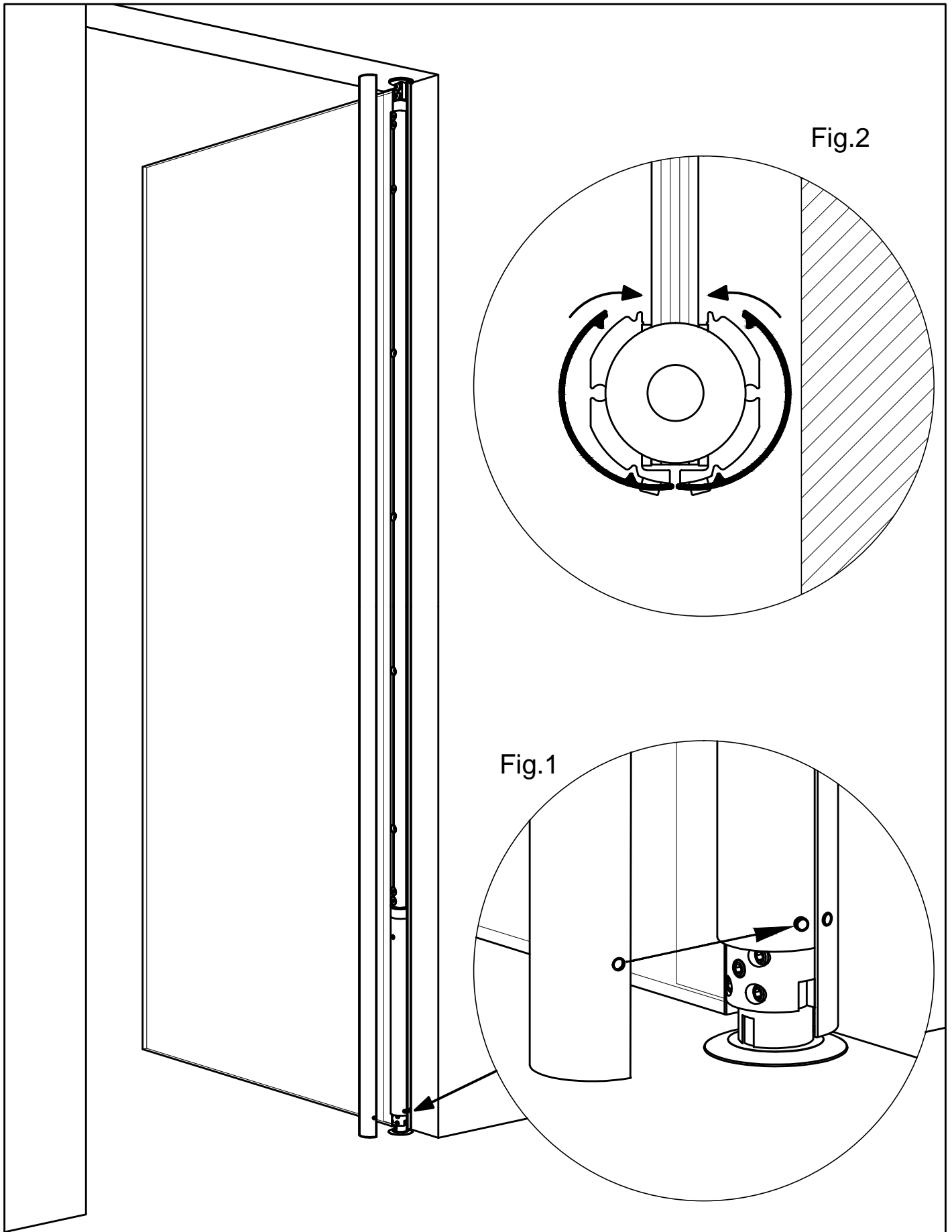

Fig.2

Fig.1

D1.17

ZENITH D1 - COVER PLATES

BEFORE FASTENING COVER PLATES, FIX THEM USING THE SUITABLE SCREWS (Fig.1) AND THEN ROTATE THEM UP TO THE HOOKING (Fig.2)